

REV	ECO	DESCRIPTION	DATE	BY	APP
D	3811	ADD LABEL	9/13/2012	GL	JK

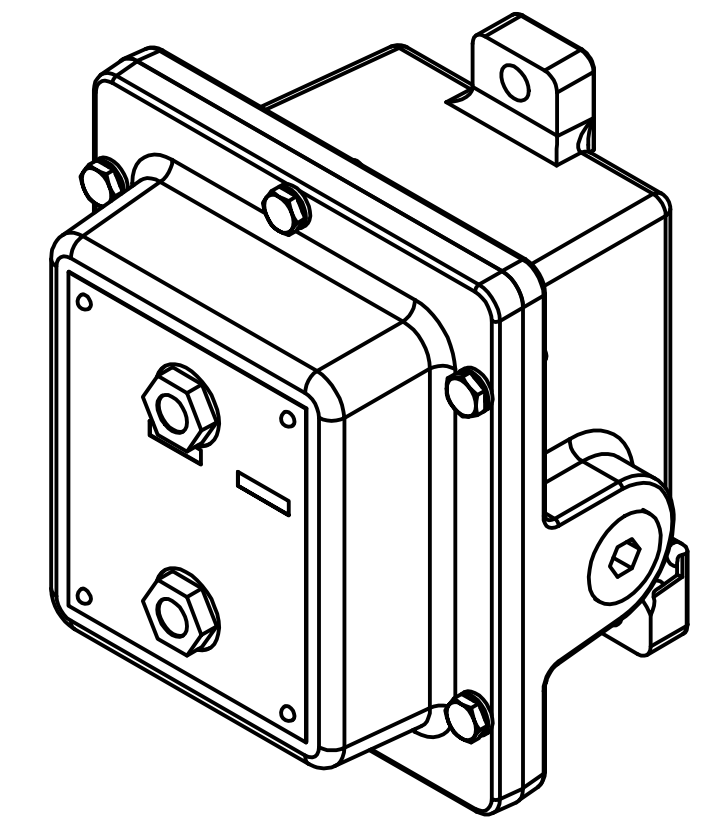

VIEW 5
SCALE 1/2

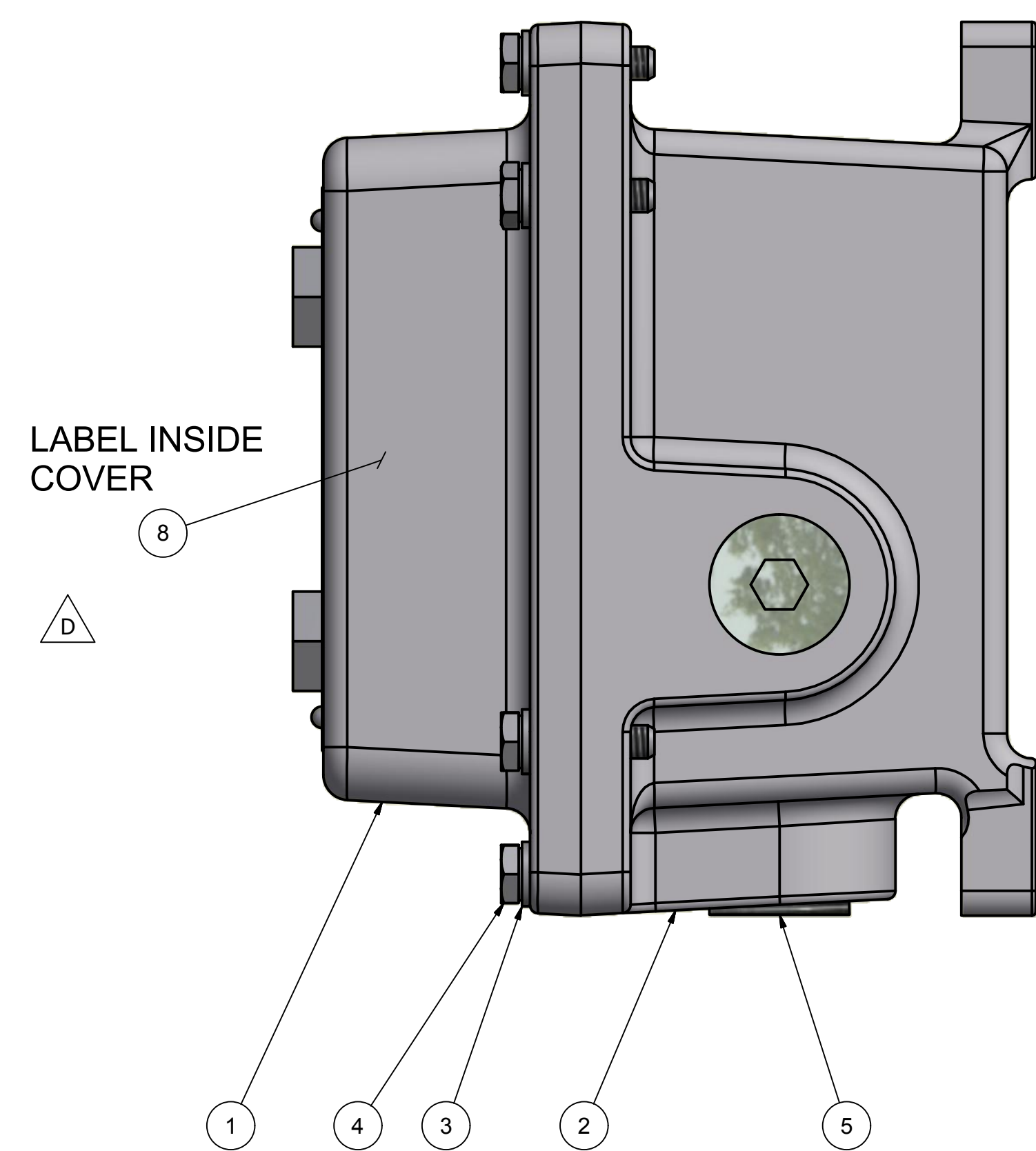
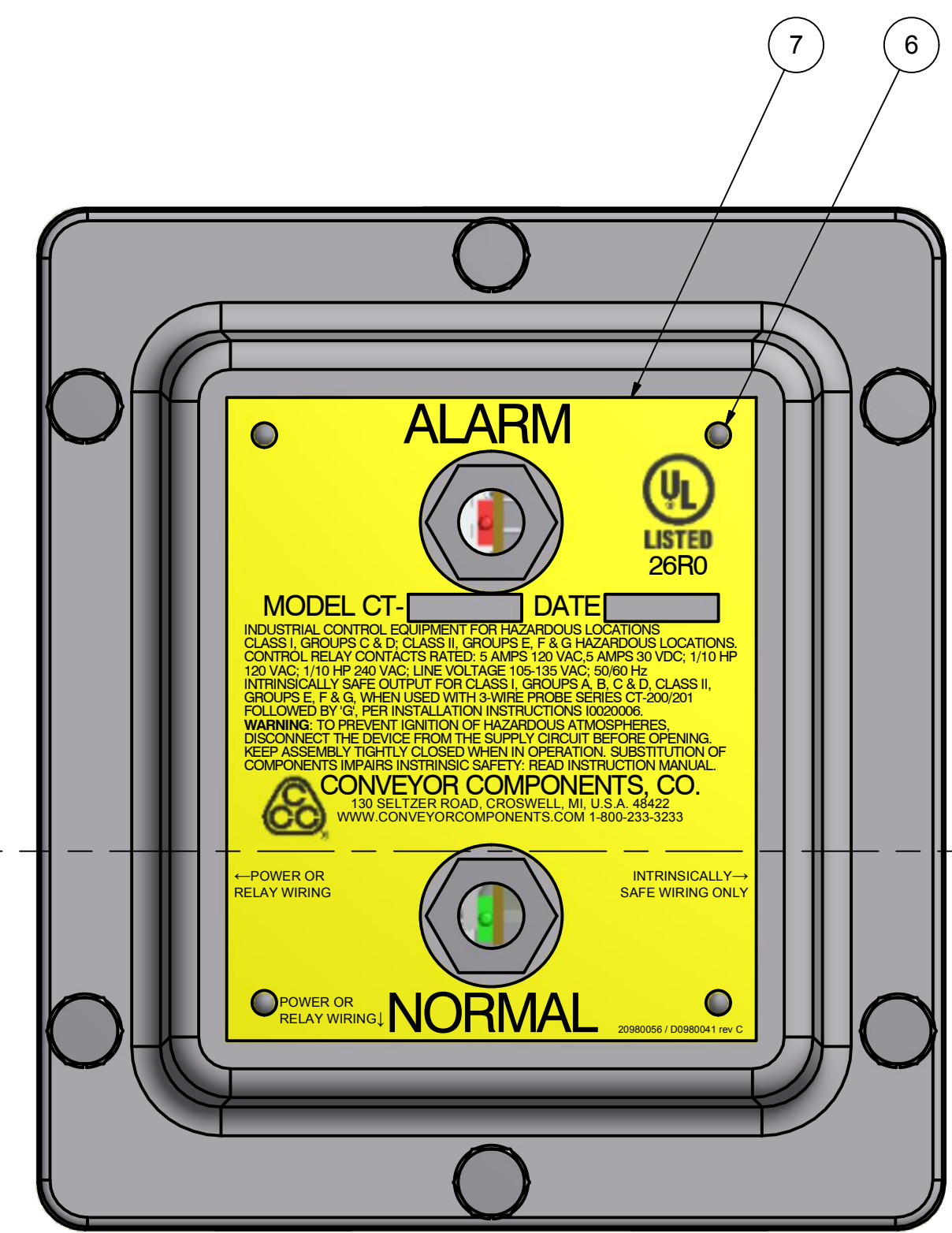

LABEL INSIDE COVER

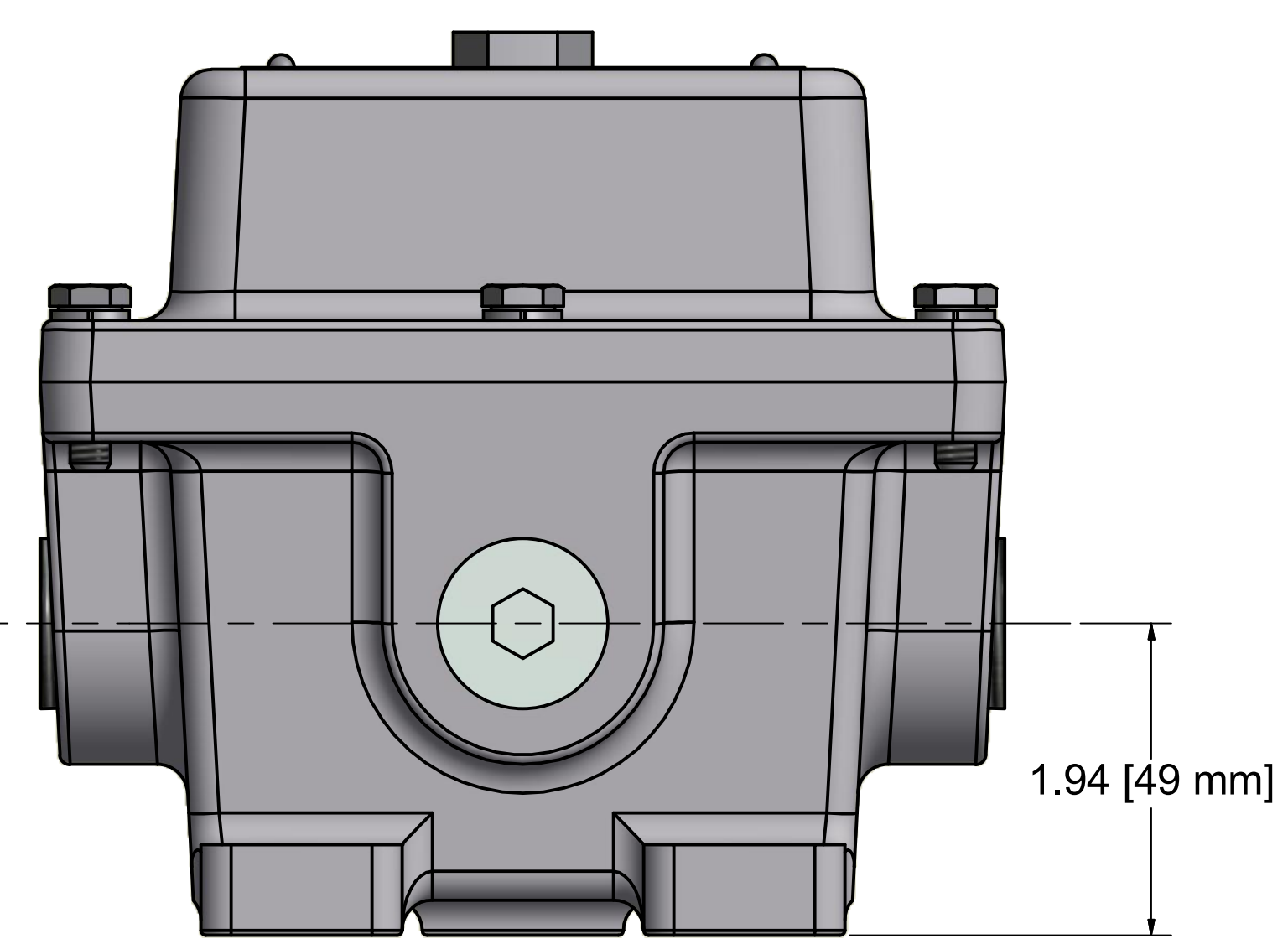
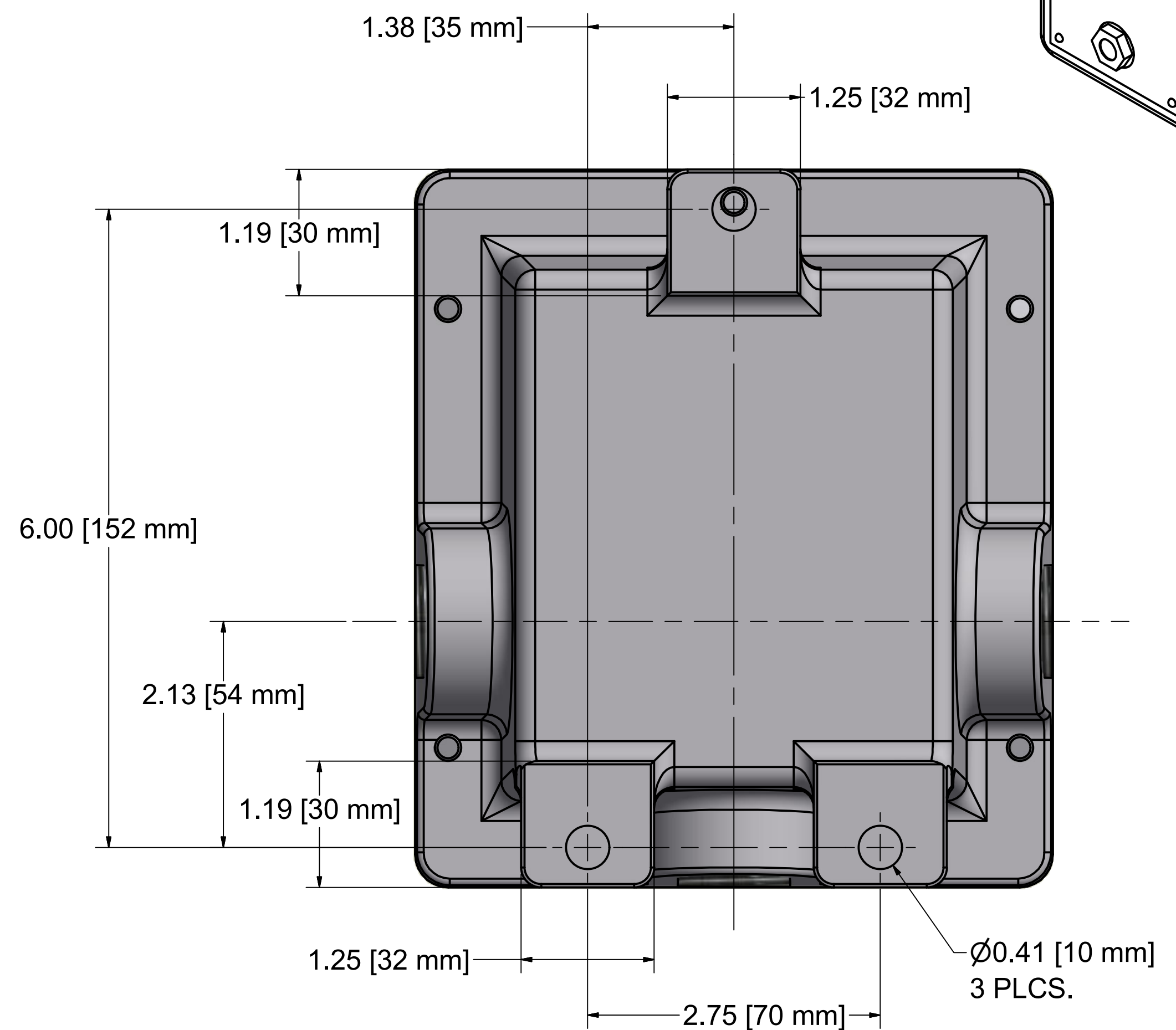

ALL DIMS REFERENCE ONLY.

ENCLOSURE TYPE: CLASS I, GROUPS C AND D;
CLASS II, GROUPS E, F AND G HAZARDOUS LOCATIONS

PARTS LIST				
ITEM	PART#	DWG	DESCRIPTION	I QTY
1	20020194	D0020038	CT COVER ASSEMBLY X-PROOF	1
2	20020191	D0020043	CT BASE ASSEMBLY X-PROOF	1
3	22013426		1/4" SPLIT LOCKWASHER - SST	6
4	22011075		1/4-20 X 1 HEX HEAD CAP SCREW - SST; UL CTRL	6
5	CT-29		3/4" CONDUIT PLUG X-P UL RC CCN EBNV	3
6	22016101		#2 X 1/4 Drive Rivet - SST	4
7	20980056	D0980041	NAMEPLATE CT CONTROL HAZARDOUS LOC, UL	1
8	20980079	D0980059	LABEL: CT CONDUCTORS / TORQUE	1

DRAWN GL	12/10/2009	Conveyor Components Company Division of Material Control, Inc. 130 Seltzer Road, Crosswell, Michigan 48422 U.S.A.
CHECKED JK	10/2/2012	
APPROVED JK	1/14/2010	TITLE
PART CT-107		CT-107 CT CONTROL EXPOSITION PROOF
THIS PRINT IS PROPERTY OF CONVEYOR COMPONENTS CO., AND MAY NOT BE USED IN WHOLE OR PART WITHOUT WRITTEN PERMISSION.		
SIZE D	DWG NO D0020030.dwg	REV D
SCALE		SHEET 1 OF 1